

Truck-mounted concrete pump

BSF 47-5.16 H

.16 H LS

Output up to 160 m³/h
 Delivery pressure up to 130 bar*

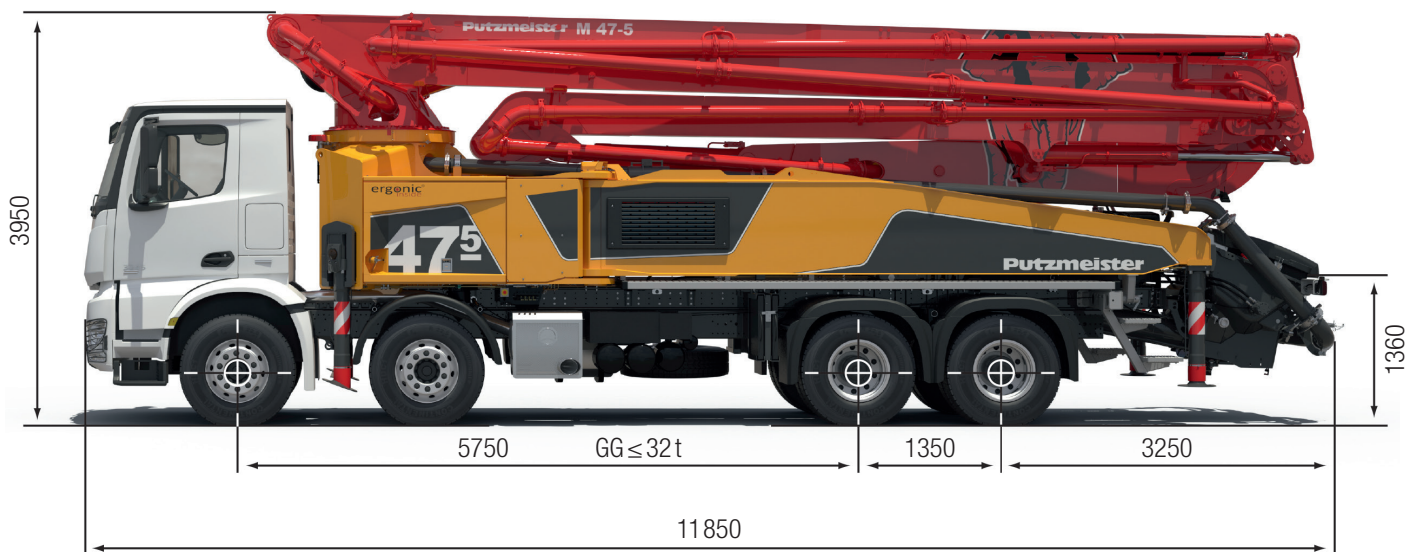
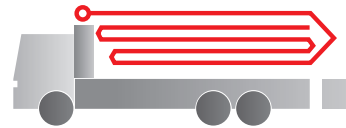

Note: Standard version. Dimensions and weights depend on truck, pump model and equipment.
 Dimensions in mm, MB-Arocs 4143 as example.
 For illustration only.

Technical data

Boom M 47-5		
Sections		5
Reach height	m	46.1
Horizontal reach	gross	m 41.1
	net	m 38.0
Reach depth max.	m	32.4
Unfolding height	m	11.1
End hose length	m	3
Folding system		RZ
Delivery line		DN 125

Pump		BSF	.16 H	.16 H LS
Rod side	Output	m ³ /h	160	–
	Delivery pressure	bar	85	–
	Strokes	1/min.	31	–
Piston side	Output	m ³ /h	108	160
	Delivery pressure	bar	130*	85
	Strokes	1/min.	21	26
	Delivery cylinder	Ø mm	230	250
	Stroke	mm	2100	2100

*) Delivery line boom max. 85 bar.
 All data maximum theoretical.

Reach information diagram

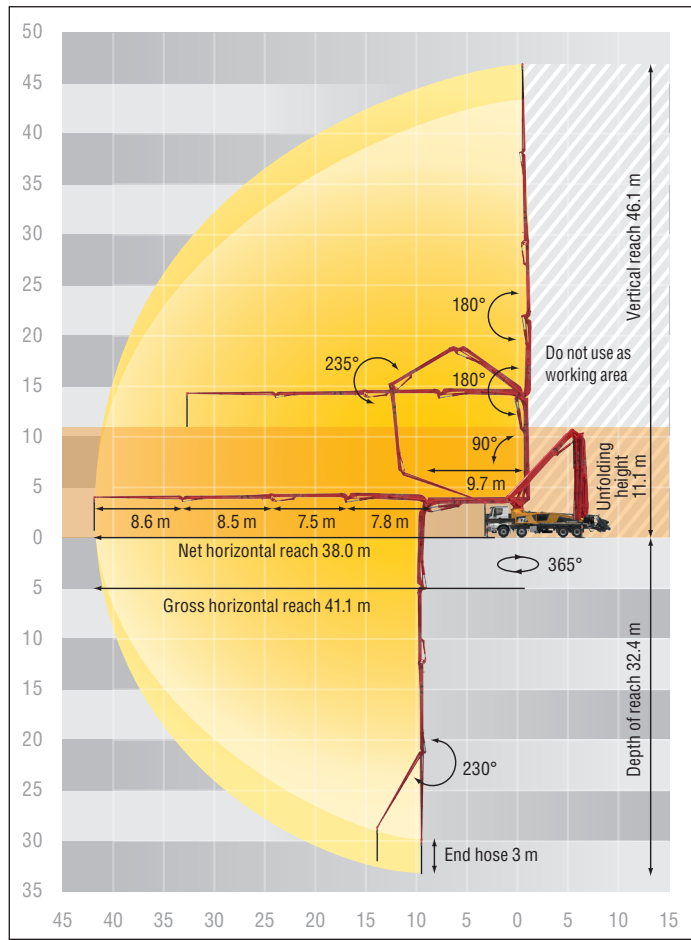

Support

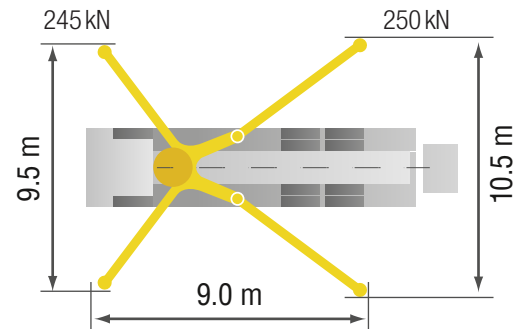

ESC

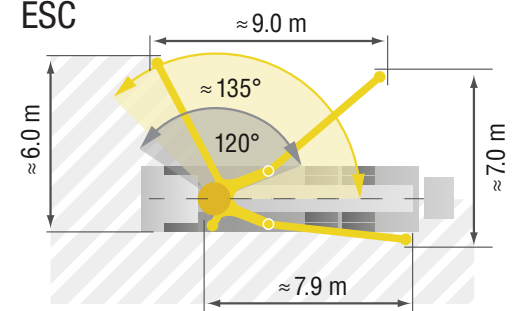

OSS

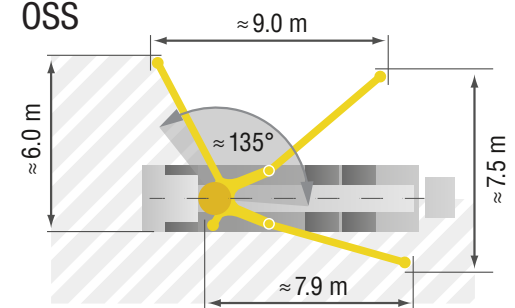

Delivery scope Standard Line

Adjustment options with machine fault management (EGD-RC)	EPS – Ergonic Pump System	Painting: 3-coloured Putzmeister standard
Agitator safety switch off, with startup protection	Ergonic 2.0	Platform non-skid
Bolted I-frame	Ergonomic water hose reel at riser pipe	Radio remote control ergonic 2.0 with display, also using with cable
Bolted pipe holders	Fail-safe S transfer tube	Rubber collar on concrete hopper
Boom rest RFID-monitored	Flushing water pump 160 l/min 25 bar	S-transfer tube switchover fast/slow
Box for sponge balls	Fully enclosed side for simple cleaning	Spectacle wear plate DURO 22
CAN-Bus system	Hand rail at water tank, right hand side	Splash guard foldable
Cardan shaft maintenance free	Hinged elbow with cleaning port	Support plates (4x)
Combined lubrication: auto lubrication of hopper, A-joint and slewing ring. Cycles adjustable.	Hose for cleaning 10m incl. bracket and spray nozzle	Wash-out port lid with secured sliding pin
Concrete hopper with agitator	Hydraulic fluid cooler integrated in the support leg	Water supply at hopper
Connection for filling water tank	Hydraulic hose for replacement in hose pack	Water tank 800 l
Contamination indicator hydraulic oil filter	LED lighting control box	Wear reduced delivery line elbow with extension both sides
Delivery cylinder chrome-plated	LED lighting control sections	
Delivery note-box, plastic	LED lighting hopper	
Diagnose interface	Maintenance free pins rear support leg	
EOC – Ergonic Output Control	Maintenance-optimized support cylinder	
	Operating manuals 2x (1x paper, 1x CD-ROM), spare part list	

See quotation for exact serial delivery scope.
Comprehensive range of options available on request.